

SUBMERSIBLE NON-CLOG SEWAGE PUMP



FEATURES

- Capacity : Upto 1100 LPM
- Head : Upto 36 Mtr.
- Impeller type : Vertex / Non Clogs
- Solids : Upto 20 mm
- Max Temp : Upto 70 C
- Highly Operational Reliability.

APPLICATION

- Sewage Treatment Plant
- Sewage treatment plant
- Septic plant
- Collecting and Settling Sump
- Any where Drainage of Dirty water with rags mixed.

SPECIFICATION

MOTOR

- Two Pole induction continuous rated motor with Squirrel cage rotor and stator insulation Class F
- Rate Speed : 2800 RPM
- Power Rating : 0.75 KW/ 1.12 KW
- Three Phase AC -50 HZ ,380 to 440 volt

POWER CABLE

- Water proof / oil proof PVC insulated double sheathed copper conductor flexible cable.

SHAFT SEAL

- Mechanical Seal : Ceramic Vs. Carbon / Tungsten Vs. Tungsten Carbide.

MATERIAL

- Pumps Casting - Graded Casting FG 200
- Impeller - SS 410
- Rotor Shaft - SS 410
- Rubber Part - Nitrile SHOR - A75 ($\pm 5\%$)

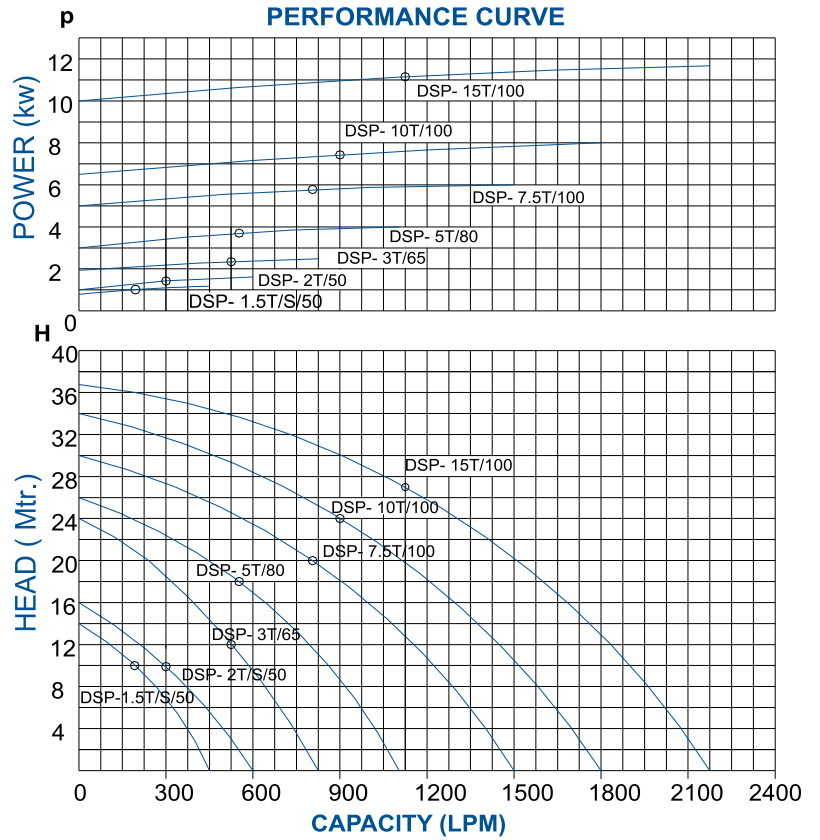
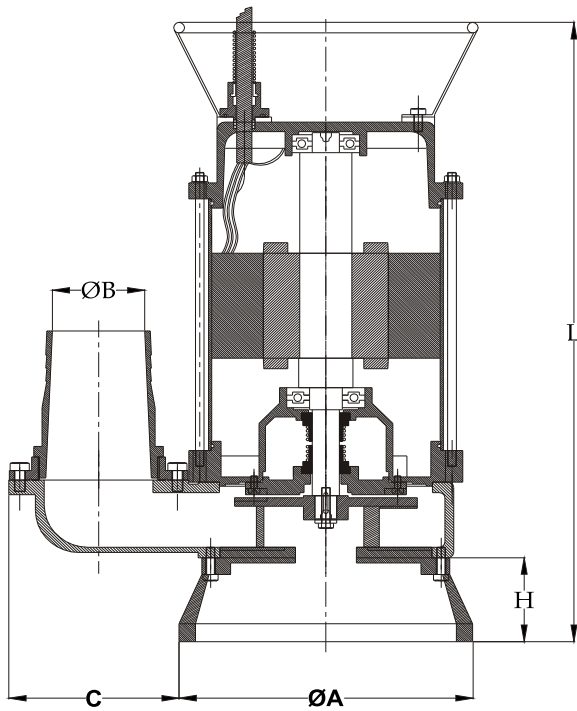

PRODUCT RANGE

PUMP TYPE	MOTOR 3Ø PHASE		DELI. SIZE	WEIGHT (APPX.) (W/O CABLE)	DISCHARGE IN LPM							Overall Dimension					
					250	300	450	550	800	900	1100						
TYPE	H.P	K.W	MM.	KG.	Working Range							L	C	ØA	ØB	H	
					HEAD IN METER												
DSP-1.5T/S/38	1.50	1.12	50mm.	35 Kg	10	06	-	-	-	-	-	-	530	100	185	50	70
DSP- 2T/S/50	2.00	1.50	50mm.	43 Kg	12	10	06	02	-	-	-	-	470	125	240	50	70
DSP- 3T/65	3.00	2.25	75mm.	50 Kg	20	15	12	09	02	00	-	-	470	125	240	65	70
DSP- 5T/80	5.00	3.75	100mm.	77 Kg	24	22	20	18	12	08	-	-	570	160	270	80	65
DSP-7.5 T/100	7.50	5.75	100mm.	83 Kg	28	27	26	24	20	18	13	-	600	160	270	100	65
DSP- 10T/100	10.0	7.50	100mm.	95 Kg	33	32	30	29	26	24	20	-	630	160	270	100	65
DSP- 15T/100	15.0	11.25	100mm.	100 Kg	36	35	34	33	31	30	27	-	650	160	270	100	65

Due to continuous product research & development specification may be change without any notice



981, Dhiraj Niwas. Nr. Mahakali Hotel Laheripura New Road.

Vadodara - 390 001. Contact: (M) 98259 52159

Visit: www.pumphouse.co.in

Email: pumphouse98@gmail.com

